

T388CC

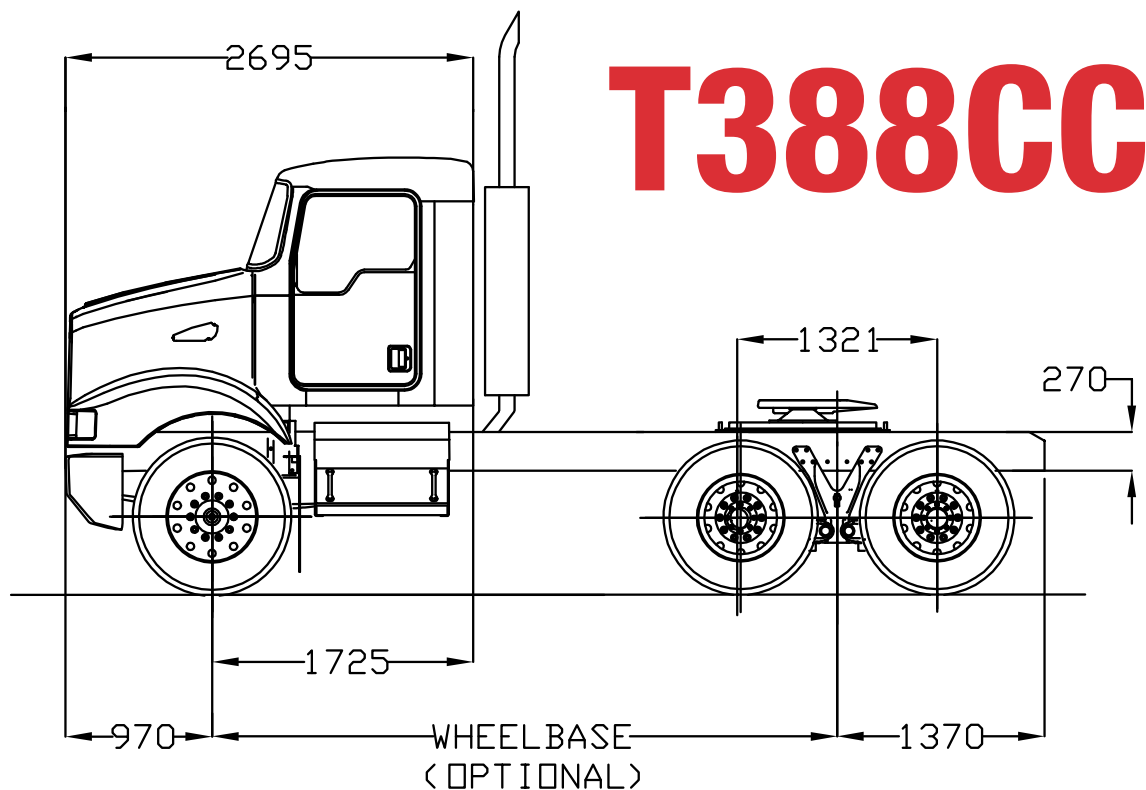

AUSTRALIAN MADE. WORLD'S BEST.

Vehicles shown may include some non-standard optional equipment.



T388CC

Purpose designed and built to deliver for the Car Carrying industry, the T388CC has been based on proven design specifications including suspensions, axles and gantry mounts. With your bottom line in mind, this truck is packed with features you would only find on a Kenworth.

MAIN SPECIFICATIONS AND OPTIONS

CONFIGURATION

6 X 4

ENGINE

CAT C13 410HP 1450/1650lbft
CAT C13 430HP 1650lbft
CAT C13 470HP 1650lbft

FRONT AXLES

Meritor FG943 5" Drop Axle 6.6t
Meritor FG941 6.6t
Dana E-1322 6t

SUSPENSION

Hendrickson HAS461 8" ride height
Air Glide 400 18.1t cap

TYRES

Bridgestone 305/70 R22.5 R227 - 2 x steer
Bridgestone 305/70 R22.5 M729 - drive
Bridgestone 295/80 R22.5 R150 II - 2x steer
Bridgestone 275/70 R22.5 R294 - 2 x steer
Bridgestone 295/80 R22.5 M722 - drive
Bridgestone 275/70 R22.5 M711 - drive

WHEELS

Alcoa 8.25" - 285 PCD
Steel Disc Wheels 8.25" - 285 PCD
Alcoa 8.25" - 335 PCD

EXHAUST

Single exhaust, post mounted outboard LHS
Single under chassis mounted exhaust w/ RH discharge

FRONT SPRINGS

Front springs, 6.5t taper leaf

BUMPER

Painted steel bumper
Brushed aluminium bumper
FUPS Compliant bumper

MIRRORS

Flat mirrors - heated
Spotter mirrors below main(2)
Peeper window LHS spotter mirror
Flat mirrors - heated with moto mirror

TRANSMISSION

A range of manual and autoshift 10, 13 and 18 speed Eaton transmissions to suit a wide variety of applications and engine torque requirements.

REAR AXLES

A range of heavy duty steer and drive axle options from Dana and Meritor are available to suit various applications and GCM requirements.

CABINS

Huckbolted aluminium frame with aluminium, steel and fibreglass rivetted construction using aerospace technology. Aluminium bulkhead type doors with continuous piano-type hinges. Cabs are ECE29 compliant.

SLEEPER OPTIONS

An array of cabin configurations is available including Day, 28" and 36" flat roof variants.

INTERIOR

Cabin appointments including aircraft style instrumentation, colour coordinated trim, woodgrain dash and heavy duty studded vinyl.