



## Tractor Chassis 6x4

**Series**  
**FTT CF85.430 (Fleet Spec)**

**GVM max. 24600 kg<sup>2)</sup>**

Engine : XE 315 Euro III version

Gross Combination Mass<sup>1)</sup> : up to 45000 kg

### Weights in Kilograms

Model	Gross Design Vehicle Mass <sup>2)</sup>		Total	Chassis and Cab Weight		
	Front	Rear		Front	Rear	Total
<b>Day Cab</b>						
FTT CF 85...365	6500	18100	24600	4407	2800	7207

**Chassis and Cab Weight calculated with:** F230 tilt Day Cab, with 4 coil spring suspension, XE 315 engine, 2 x 175 Ah batteries, 16 S 181 gearbox, RT40-145 rear axles, 152N front axle, 260 mm chassis rail depth, parabolic spring front suspension, Airglide 200 rear suspension, 2 x 340 litre aluminium fuel tank, steel wheels, 295 / 80 R 22.5 steer tyres, 11 R 22.5 drive tyres.

### Dimensions in metres

WB	TL	VA	AE	AC	CB	CA	CE	CH	HV <sup>3)</sup>	HA <sup>4)</sup>	WT	RB	SB	TB
<b>Day Cab</b>														
3.65	6.66	1.38	1.63	0.39	0.24	3.05	4.65	1.96	0.91	0.98	1.37	0.86	1.82	2.49

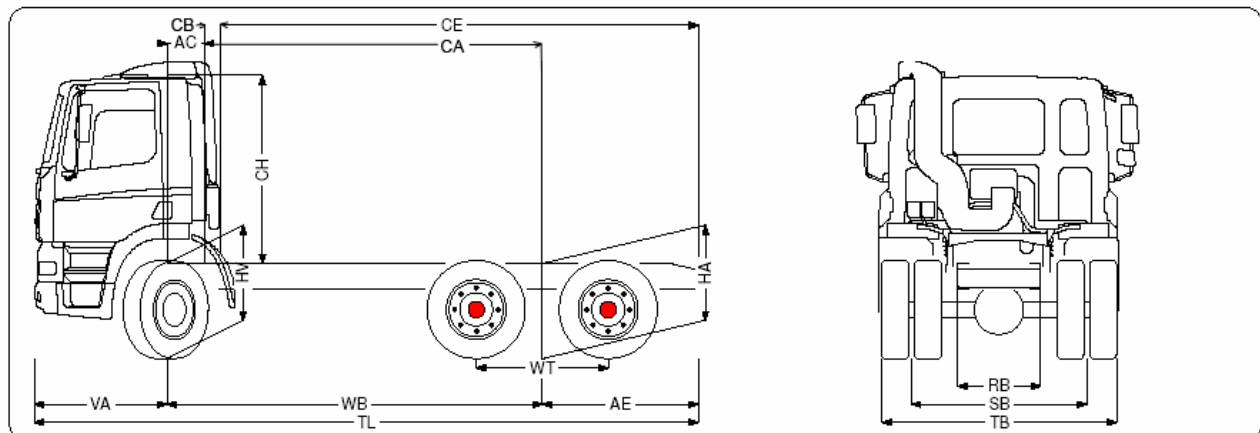

1) Subject to application approval.  
 2) Front axle load based on tyre load index.

3) Laden height at centre of front axle.  
 4) Laden height at centre of tandem axle.

